

B.31 EPS CORE REFRIGERATED BUILDINGS

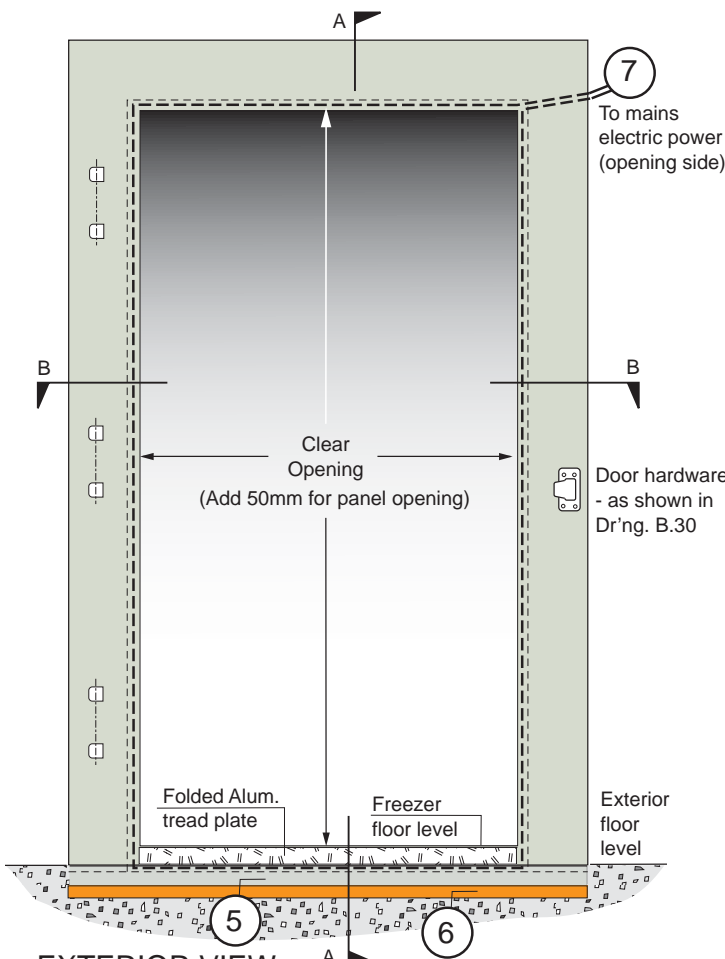

EXTERIOR VIEW
SCALE 1:20

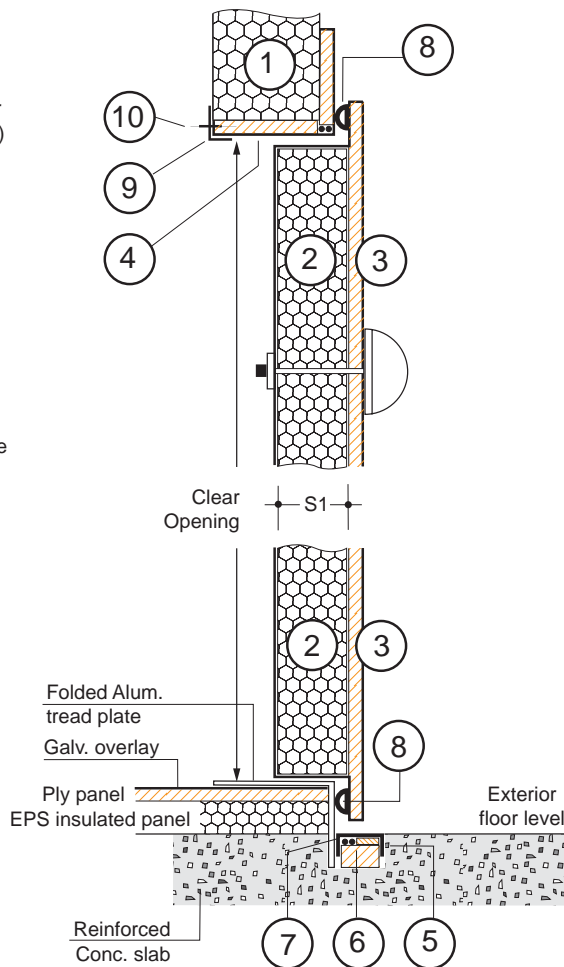

A - A CROSS SECTION
SCALE 1:10

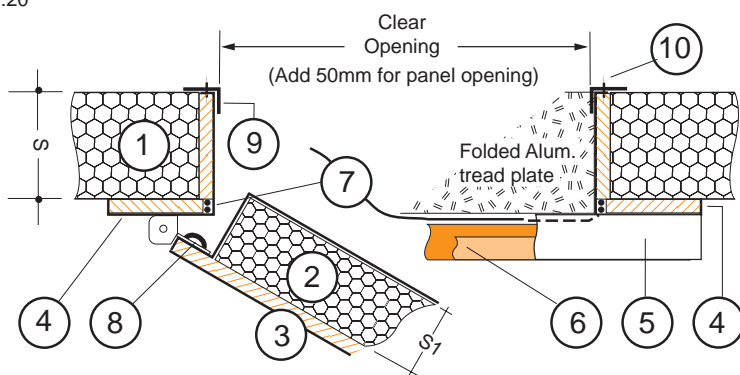

B - B
CROSS SECTION
SCALE 1:10

1	ECONOTILT PANEL	S= mm	
2	INSULATED CORE PANEL	S1= mm	
3	DOOR SURFACE	Colorbond sheet steel over 19mm Marine (8) ply & EPS core (S1)	
4	DOOR FRAME	Colorbond sheet steel over 19mm Marine (8) ply frame	
5	CHANNEL	55 x 30 x 2mm	ALUMINIUM
6	TIMBER PACKING	50 x 35mm & 32 x 7mm	MERANTI
7	RECESSED HEATER WIRES	30 watts / metre	INSULATED CABLE
8	PRESSURE SEAL	atchd. to door surface (4 sides)	MOULDED RUBBER
9	ANGLE	50 x 25 x 2mm	ALUMINIUM
10	POP RIVET mm	
POS	ITEM & DIMENSIONS		MATERIAL



Econotilt™ Panel
HINGED FREEZER DOOR FRAME
(with recessed heater wires)

25.09.03
SCALE:
various